

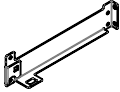

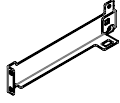



A	B	C	D	E	F	G
						
Guide holder, left x1	Guide holder, right x1	Guide bars x1	Shelf bracket x2	Lock plate x2	Spring x2	Rivet x2

①

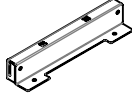
Consider the layout before assembly and installation. We recommend the following to achieve adequate rigidity in a racking installation with pull-out shelves:

- 1) Use a fixed shelf or one with a work bench at the top.
- 2) Connect the lower part with a shelf, support rail or similar.
- 3) Reinforce with additional fixing brackets (front and/or rear) against the wall.

Examples:

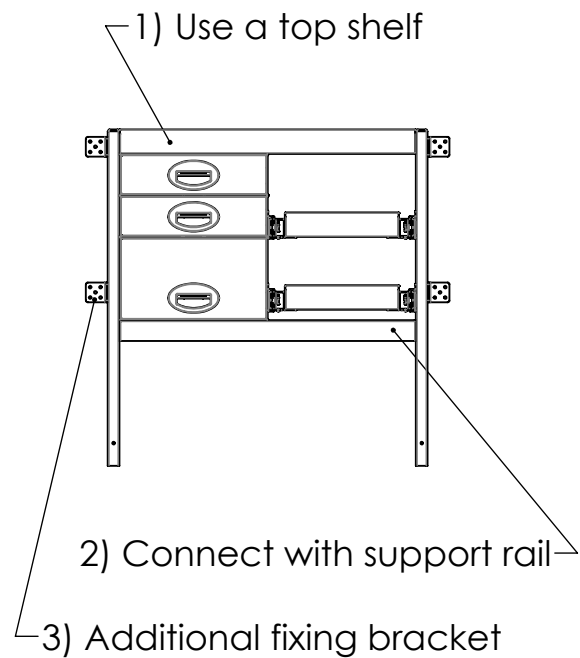
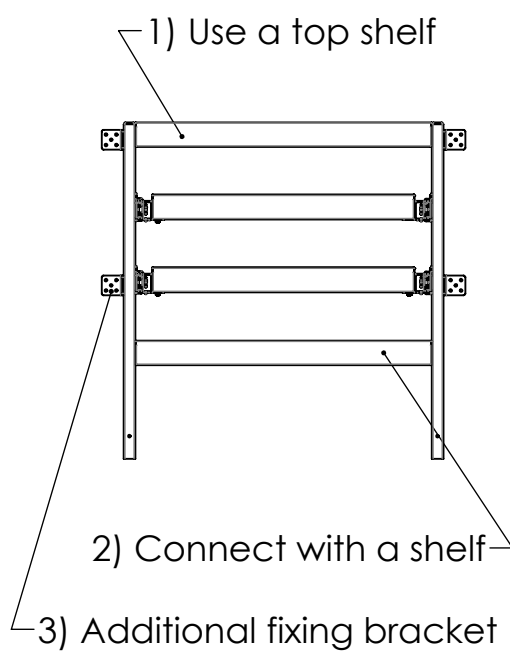

② Mount the guide holders in the shelf frames.

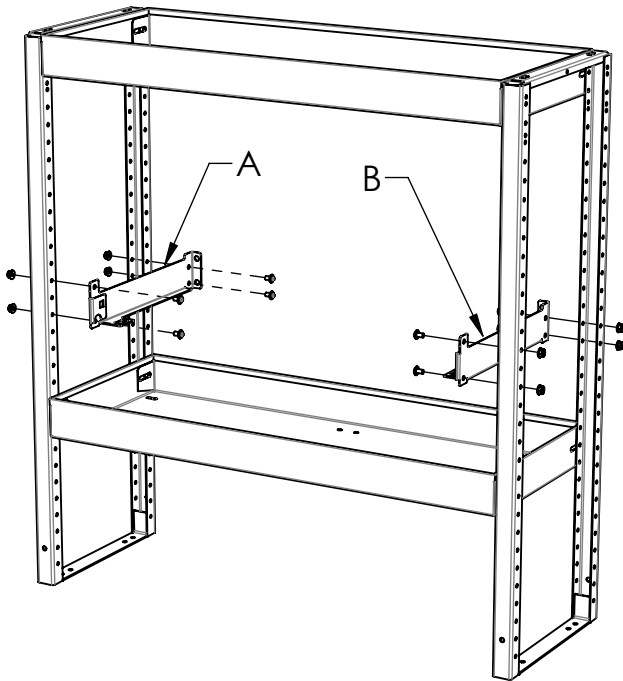

③ Mount the guide bars in the guide holders.

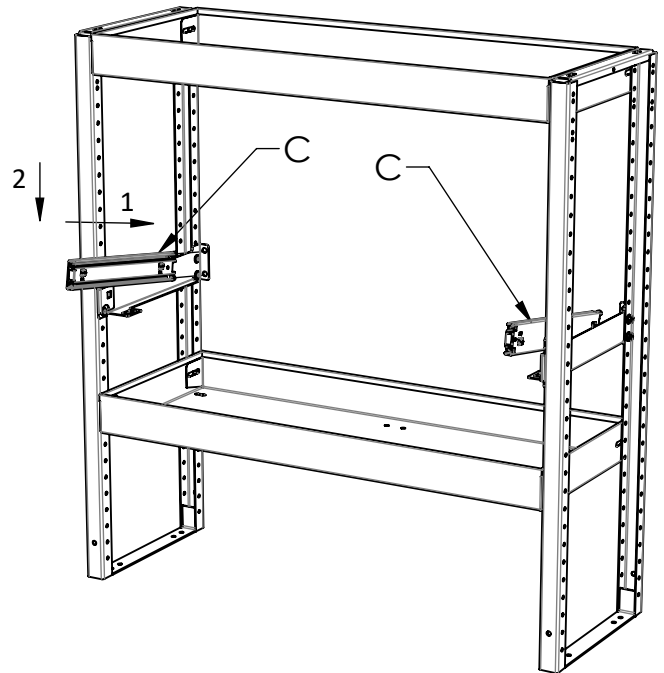

④ Plan where the lock plate(s) should be. Push down the corresponding tab on the shelf bracket about 45 degrees. Left side example:

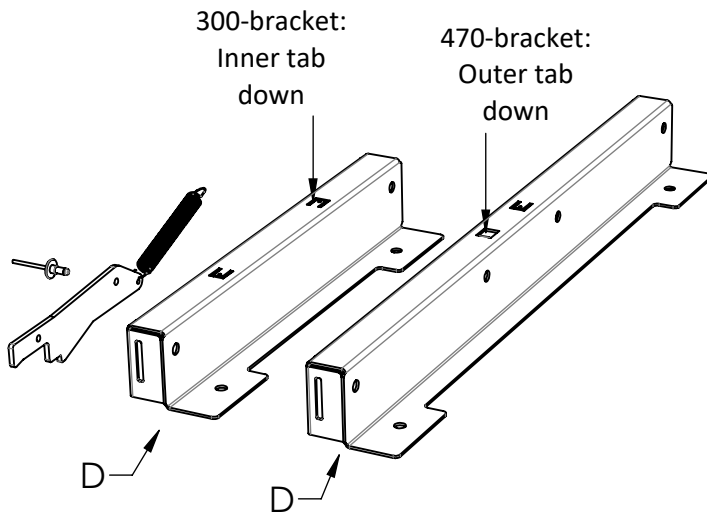

⑤ Fasten the lock plate with the rivet (1). Fasten the spring in the shelf bracket tab (2).

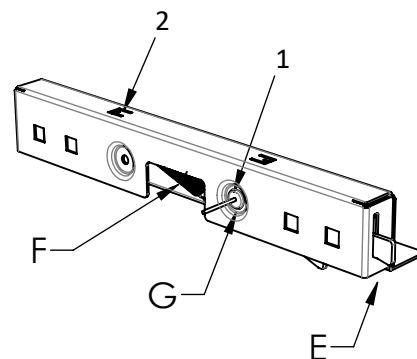

- ⑥ Mount the shelf brackets with lock plates on the guide bars.

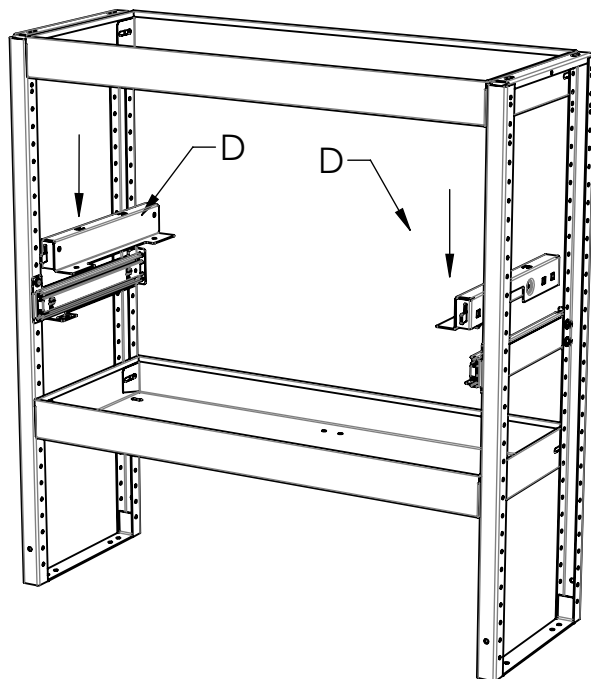

- ⑦ Mount a shelf or a board between the brackets.

